

# 80 VJR / 100 VJR









TECHNICAL DATA SHEET



 **MANITOU**

[www.manitou.com](http://www.manitou.com)

# 80 VJR / 100 VJR

	80 VJR	100 VJR
 <b>Working height</b>	7.70 m	9.90 m
<b>Platform height</b>	5.70 m	7.90 m
<b>Articulation height</b>	4.23 m	6.67 m
<b>Outreach</b>	3.25 m	3.15 m
 <b>Jib tilting</b>	+70° / - 70°	
<b>Basket rotation</b>	+70° / - 70°	
<b>Turret rotation</b>	350°	
 <b>Capacity</b>	200 kg	
<b>Number of persons (indoor/outdoor)</b>	2/1	
<b>Basket (width and length)</b>	0.90 x 0.75 m	
 <b>1. Overall width</b>	0.99 m	
<b>2. Overall length</b>	2.95 m	2.82 m
<b>3. Overall height</b>	1.99 m	
<b>4. Interior turning circle</b>	0.49 m	
<b>5. Exterior turning circle</b>	1.98 m	
<b>6. Ground clearance</b>	10 cm	
<b>7. Wheelbase</b>	1.20 m	
 <b>Speed of forward movement</b>	4.50 kph	
<b>Working speed</b>	0.65 kph	
 <b>Maximum slope accessible</b>	25 %	
<b>Maximum tilt</b>	3.5 % / 2°	
 <b>Tyres</b>	16-5-11 1/4	
<b>Driving wheels</b>	2 (back)	
<b>Steering/directional wheels</b>	2 (front)	
 <b>Weight</b>	2250 kg	2650 kg
(varies according to options & standards of the country)		
 <b>Batteries</b>	250 Ah (C5) / 24 V	
<b>Integrated charger</b>	30 Ah / 24 V	

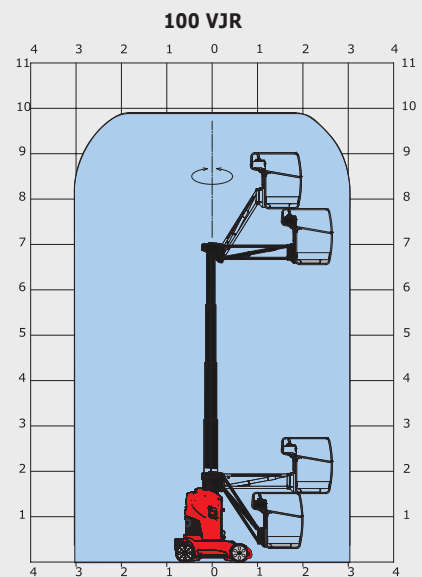
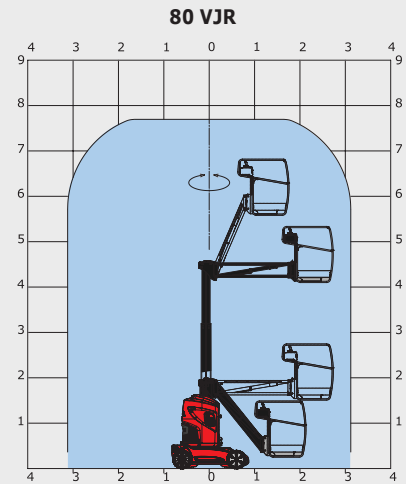

## Standard equipment

Proportional switches/levers
Forward movement possible at maximum height
Sound and visual alarm in case of excessive slant and overload
Integrated charger
Emergency manual descent
Negative braking system
Sound warning system inside the platform
Hour meter
Indication of state of charge of batteries
Hooks for sling loading/lifting
Integrated diagnostic aid
Tyres with non-marking edges
Tyres crimped non-marking wheels
All-road non-marking wheels
Basket with transparent floor
Bus CAN technology
Tool box inside platform

## Optional equipment

Flashing lights
Working light
Predisposition of air
Predisposition of water
230V power input with differential circuit-breaker
Special paint
Biodegradable oil
Central topping-up of batteries
Initial certificate of verification prior to entry into service
Safety harness
Oil for extreme low temperatures
Battery frost protection

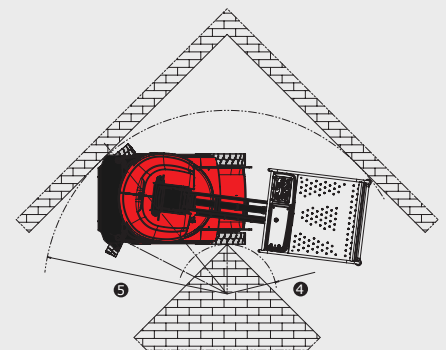
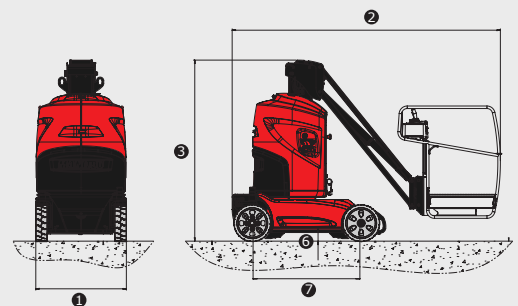

This brochure describes versions and configuration options for MANITOU products which may be fitted with different equipment. The equipment described in this brochure may be standard, optional or not available depending on version. MANITOU reserves the right to change the specifications shown and described at any time and without prior warning. The manufacturer is not liable for the specifications given. For more information, contact your MANITOU dealer. Non-contractual document. Product descriptions may differ from actual products. List of specifications is not comprehensive. The logos and visual identity of the company are the property of MANITOU and may not be used without authorisation. All rights reserved. The photos and diagrams contained in this brochure are provided for information only.

MANITOU BF SA - Limited company with board of directors - Share capital: 39,547,824 euros - 857 802 508 RCS Nantes

